



Background and Motivation

Today, misinformation is widespread on the internet. Bad actors make money off online advertising. Demand Site Platforms (DSPs) place ads on websites, and deal with misinformation by blacklisting websites from showing ads.

NOBL Media has created the Misinformation and Credible News Analysis Tool which has the capability to rate a web page's credibility and prevent ads from being placed on that page based on an advertiser-set credibility threshold. Although NOBL's service is impactful, their clients are not able to see any proof of the service.

Solution Overview

Team Truthseeker is developing the missing functionality of NOBL's analysis tool. A web application for interfacing and a REST API that gives the web application the ability to retrieve data from the NOBL database.

The web application includes:

1. User Authentication
2. Data Handling w/ Visualization
3. Campaign Selection
4. Reports Download (.csv file)

Key Technologies

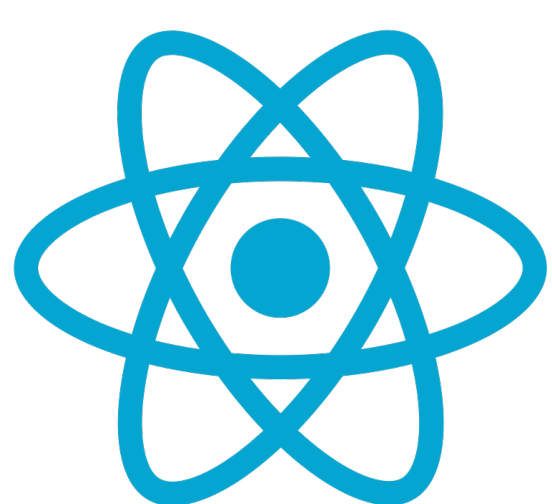

React



Auth0



ECharts

The Misinformation and Credible News Analysis Tool

Garry Ancheta, Georgia Buchanan, Jaime Garcia Gomez, Kyler Carling

Client:
Jacob Bailly, NOBL Media

Mentor:
Felicity Escarzaga

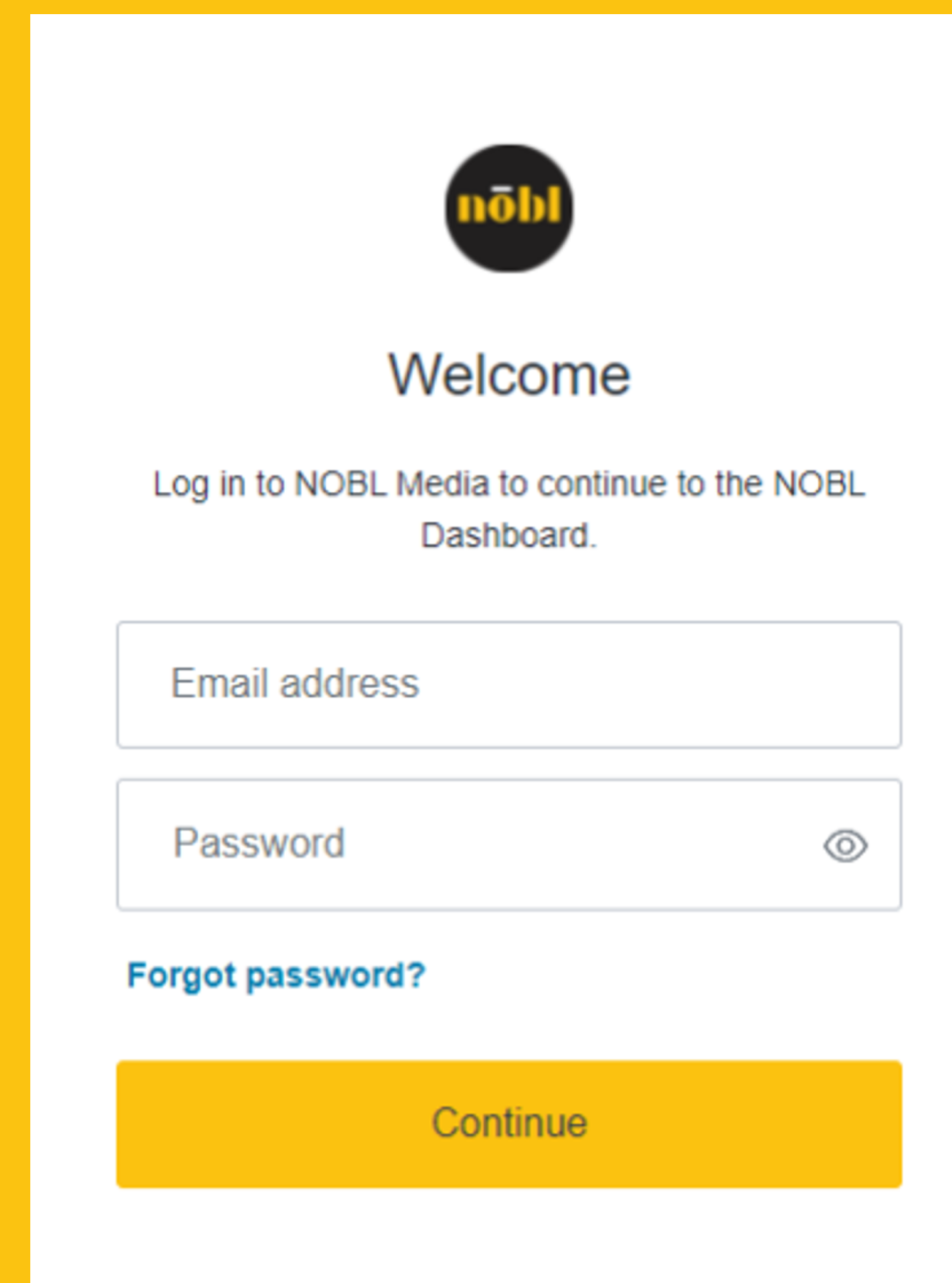

Client Login

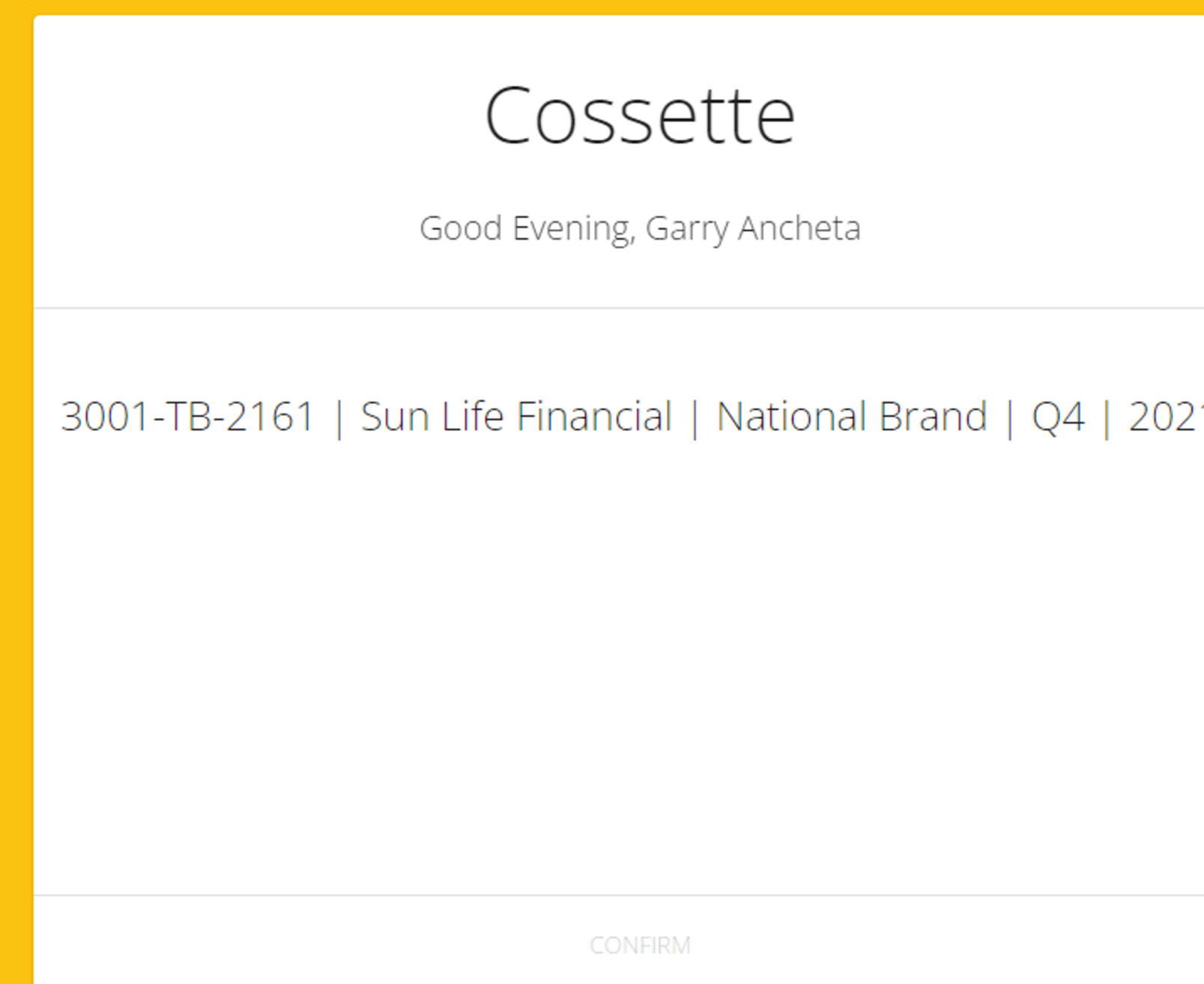

Campaign Selection



Data Visualization

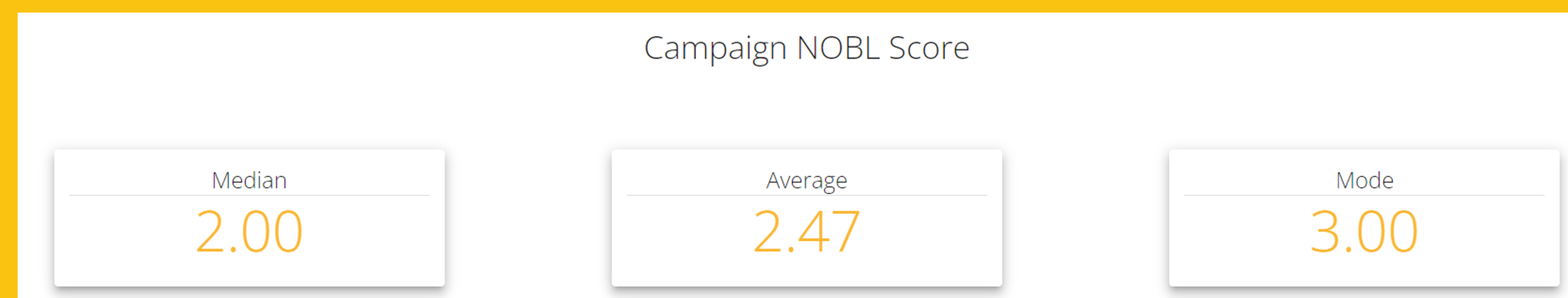

Campaign Metrics

Architectural Overview

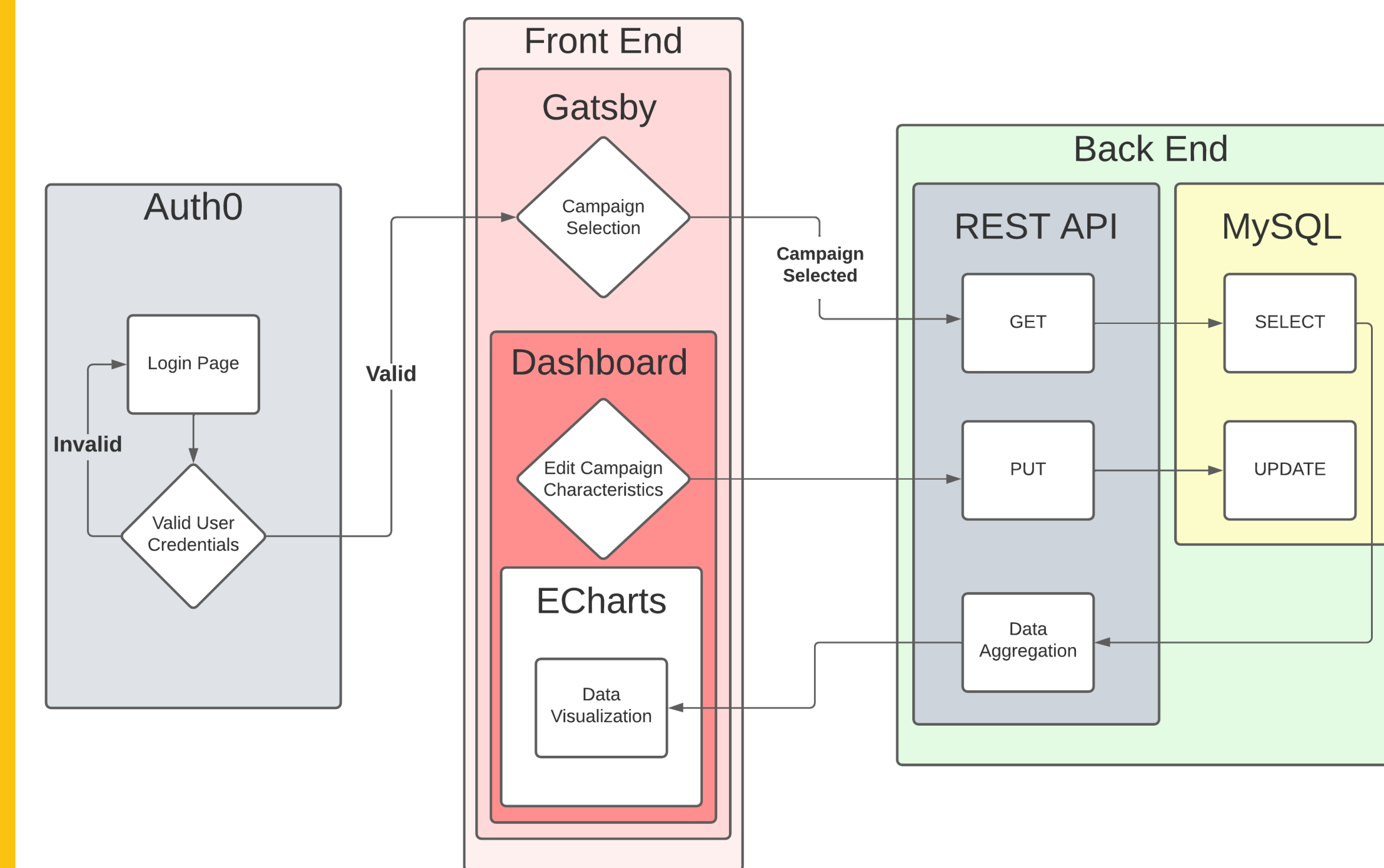

Auth0 provides a third-party turnkey authentication service. Account creations are done by NOBL rather than users.

The web application's frontend is through Gatsby, a React-based framework, and uses ECharts for its graph creation. The backend framework is Node with Express to pull data from NOBL's MySQL database.

Testing

Unit and Integration Testing

- Performed using **AVA**, a JavaScript testing framework

Usability Testing

- Simulated clients, advertising & business majors

Outcome

The web application interface that Team Truthseeker has developed for the Misinformation and Credible News Analysis Tool is a visual proof of concept for NOBL Media's clients. With this preview of NOBL Media's service, NOBL Media has a complete business workflow which is sure to attract the interest of future clients and investors.